

U:\USA Garage Tools\Work Bench\Work bench with Tube legs\RoVe WB 62 inch with 3 Drawer Tube Legs

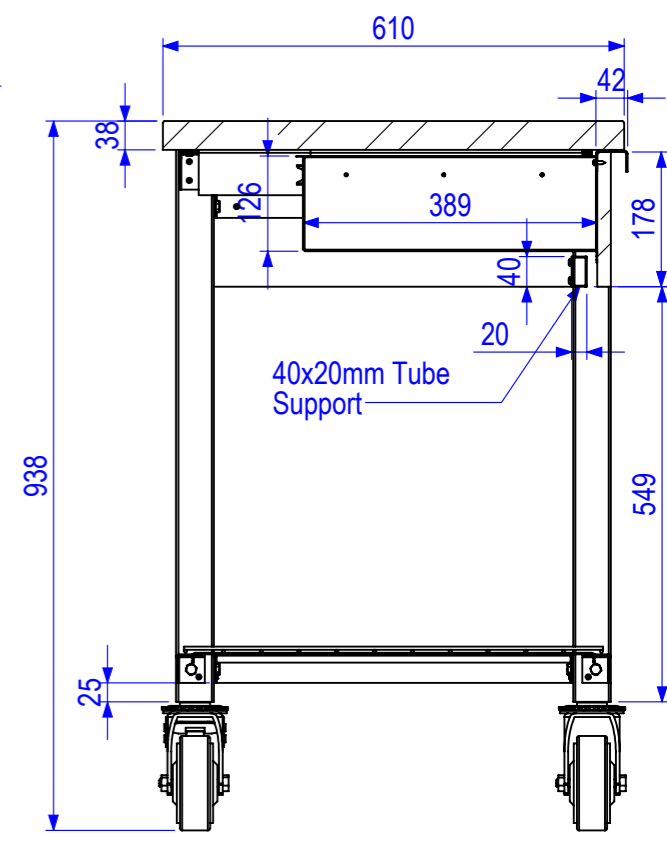

SECTION B-B

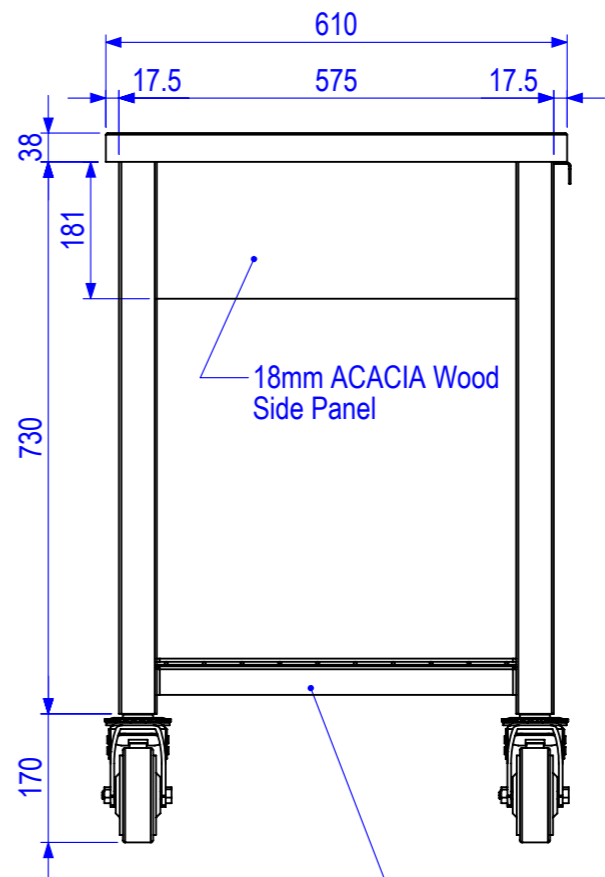
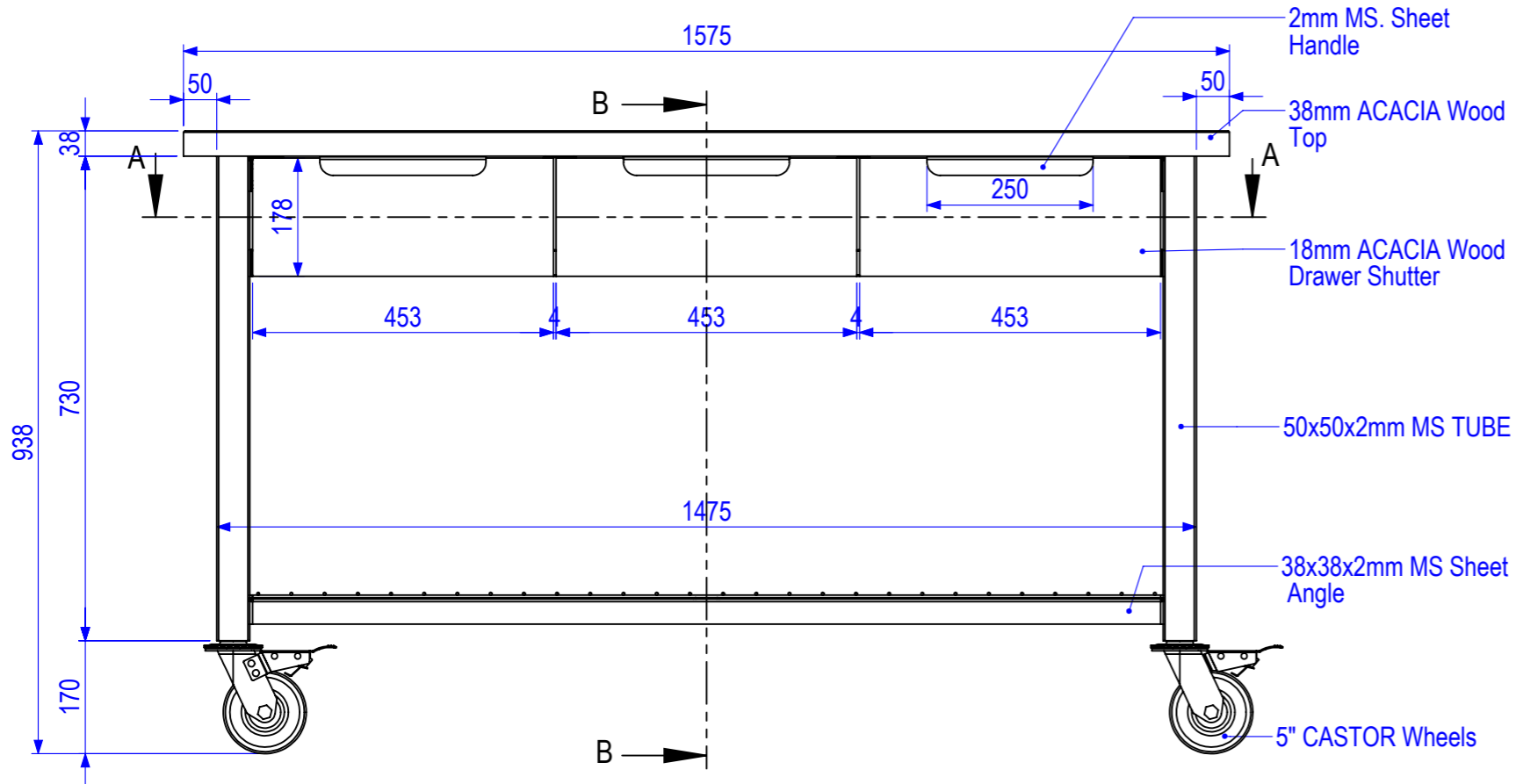
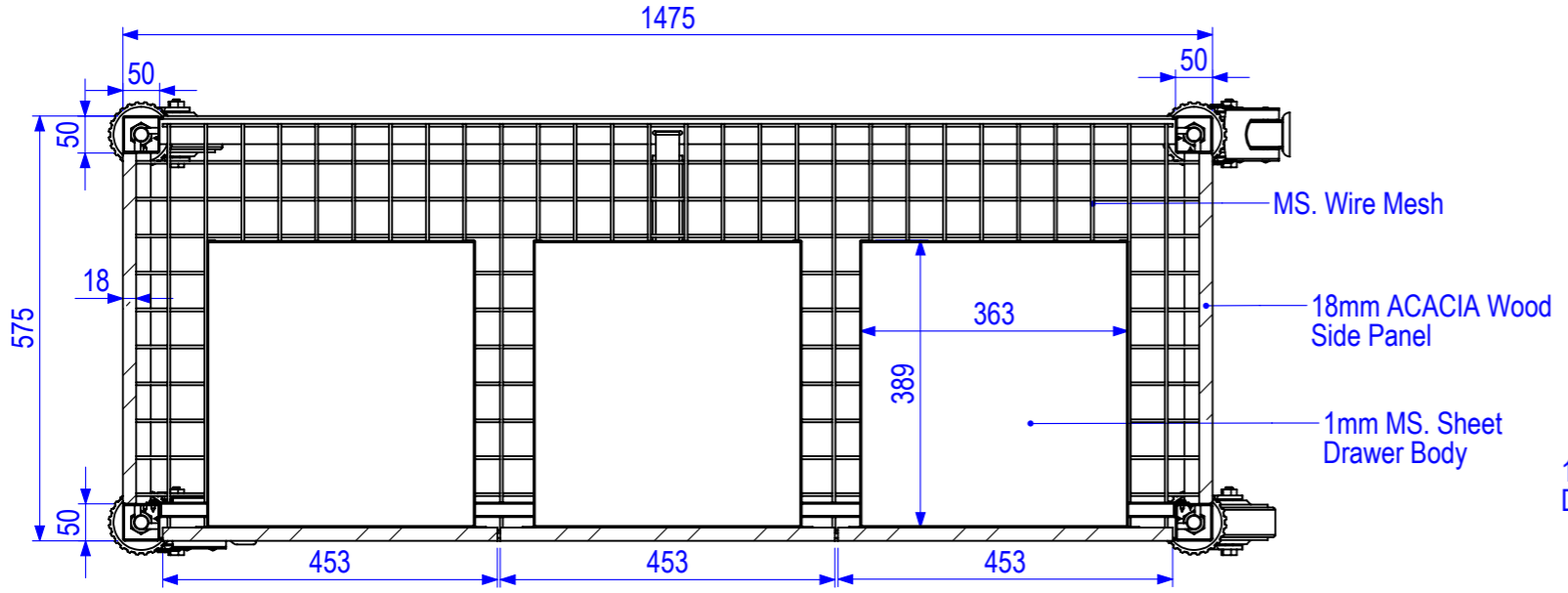

SECTION A-A

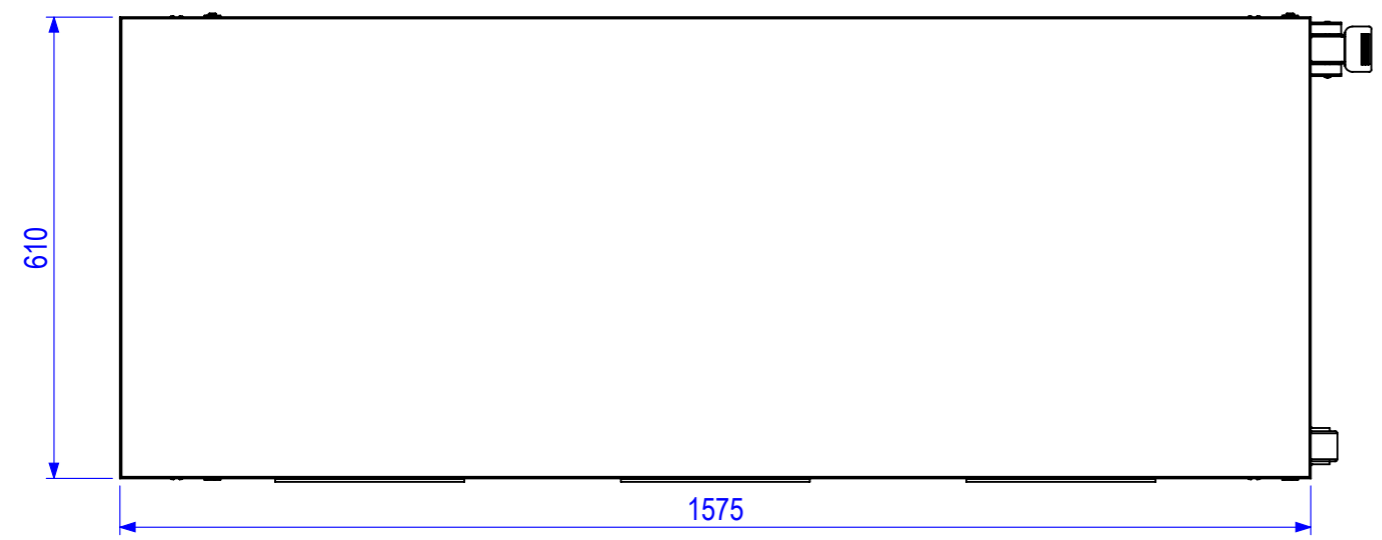
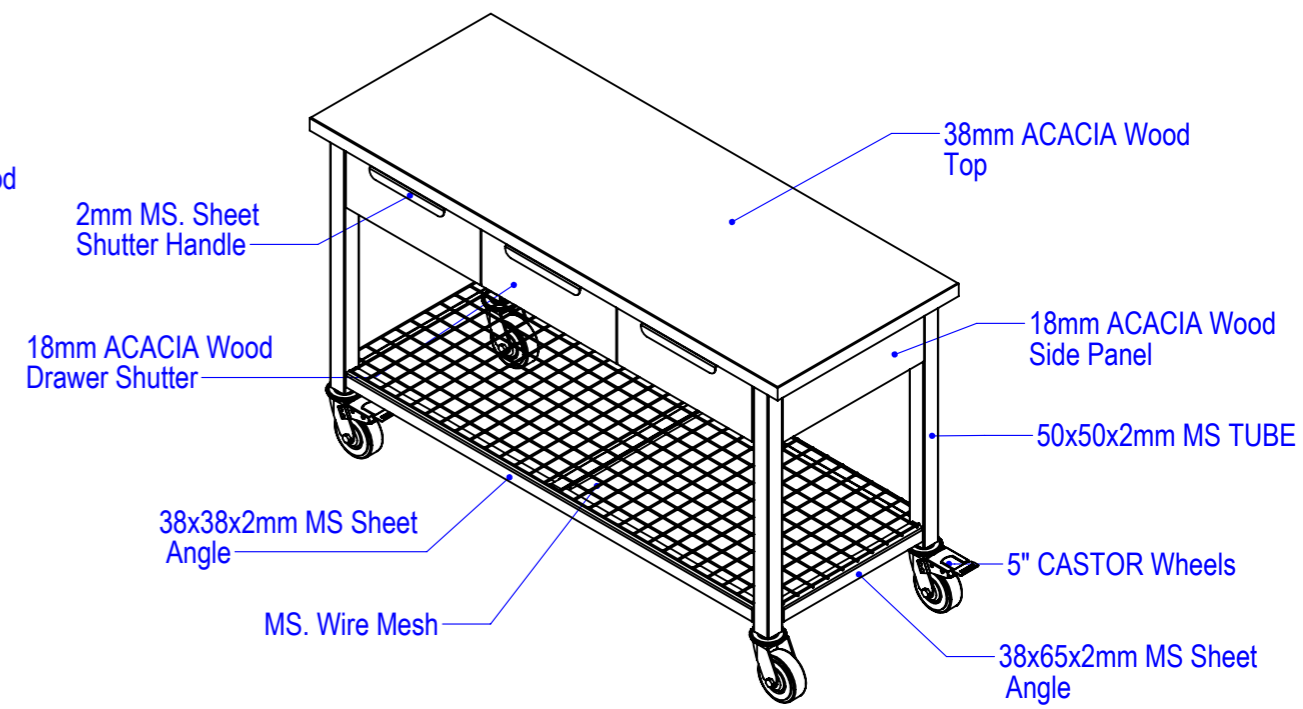

DRAWN	Tahir	SHEET THK.:	-NA-	WEIGHT:	--	S. AREA:	9263575.89mm <sup>2</sup>
CHECKED	Harout k	MAT.:	Acacia wood / Metal	FINISH:	Powder coated		
APPROVED	Raed	TITLE: <b>62" ROVE Industrial workbench</b>					
DATE	14/08/2021						
DWG. NO.	WBT62-000	PROJECT:	USA GARAGE	MODEL:	WORK BENCH 62" INCH		
General Tolerance : ± 0.1 mm				P.O. Box 474039, Jabel Ali, Dubai Investment Park - 1, Dubai (United Arab Emirates) Tel: 04-8841650 Fax: 04-8841934		SHEET 1 OF 17	
COLOUR	Black	Design & Development Department				SCALE	REV.
QUANTITY		ALL DIMENSIONS ARE IN MILLIMETERS AND ALL BEND RADII TO BE MIN. R AT 90° BEND, UNLESS SPECIFIED OTHERWISE THIS DRAWING IS THE PROPERTY OF TSSC, NOT TO BE REPRODUCED AS A PART OR WHOLE WITHOUT PRIOR CONSENT OF TSSC					
		N.T.S. 00					